

**Technical Specification**

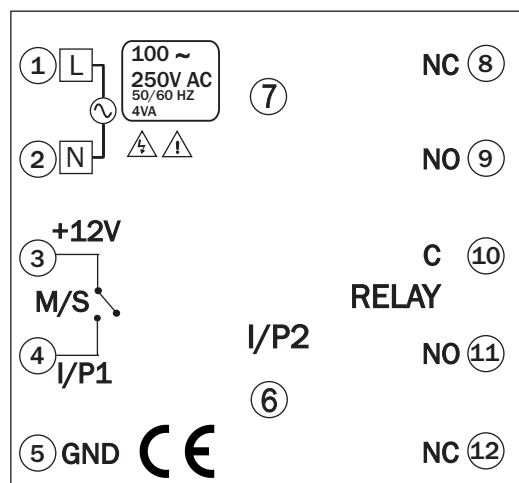

Model	PC-444		
Display	UPPER:- 4 Digit 7 seg 0.4",red LED Display LOWER:- 4 Digit 7 seg 0.3",green LED Display		
Size(HXWXD)	48 X 48 X 95 mm		
Panel Cutout	44 X 44 mm		
Input	NPN/PNP Proximity Selectable & Micro Switch		
Output	1 relay, 2 C/O contact, 230V AC, 5A		
Memory	Selectable Yes/No		
Reset	Front Reset Key		
Power Supply	100 to 250V AC, 50 / 60 Hz, Approx 4VA		
Protection Level (As per request)	IP-65(Front side) AS per IS/IEC 60529:2001		
Operating Temperature	0° C To 55° C	Relative Humidity	Up to 95% RH Non Condensing

**Connection Diagram**



## Parameter Menu

## Key Operation

- 1) Press  key, Shift to the next digit
- 2) Press  key, Increase individual digit value

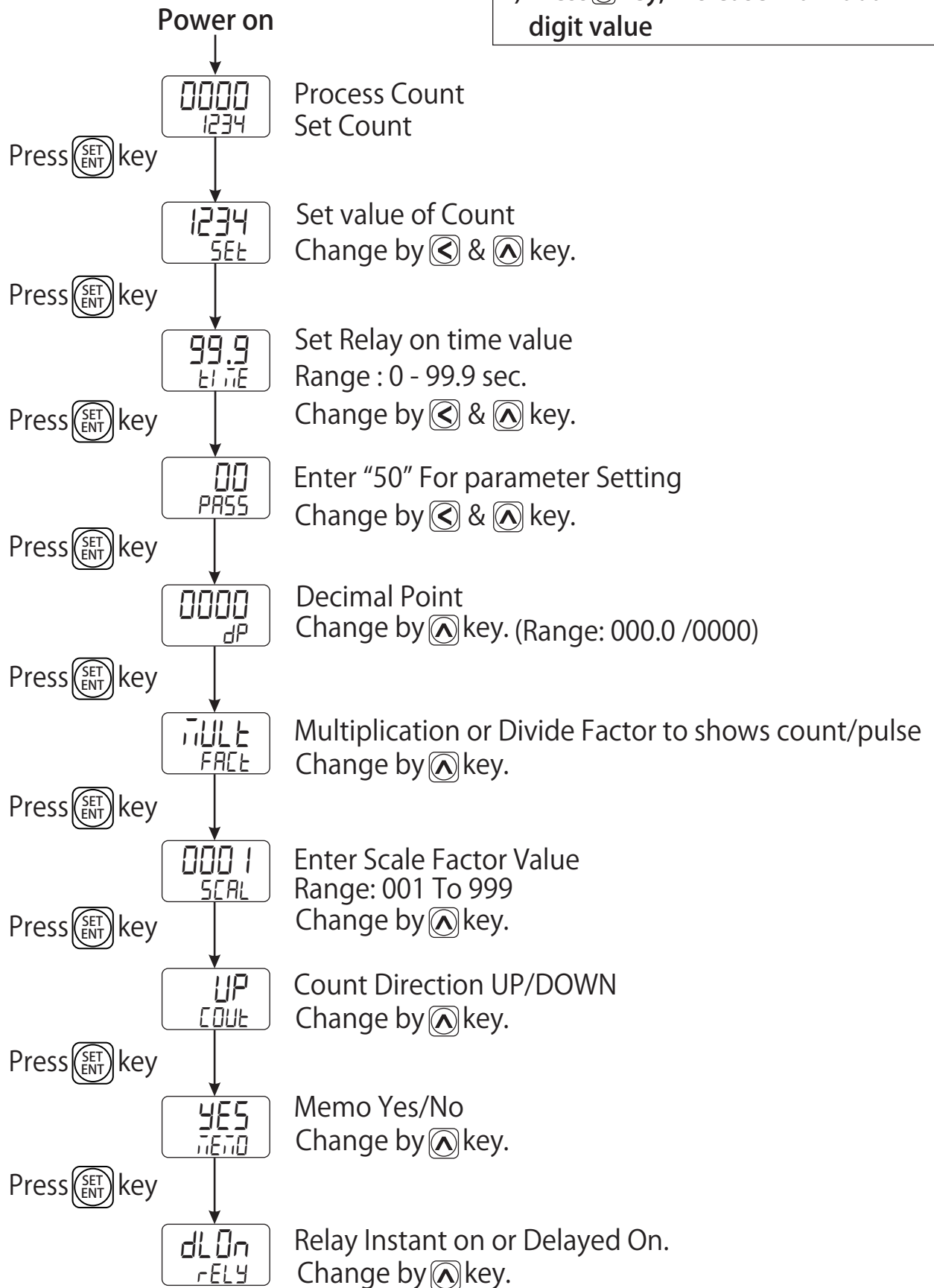

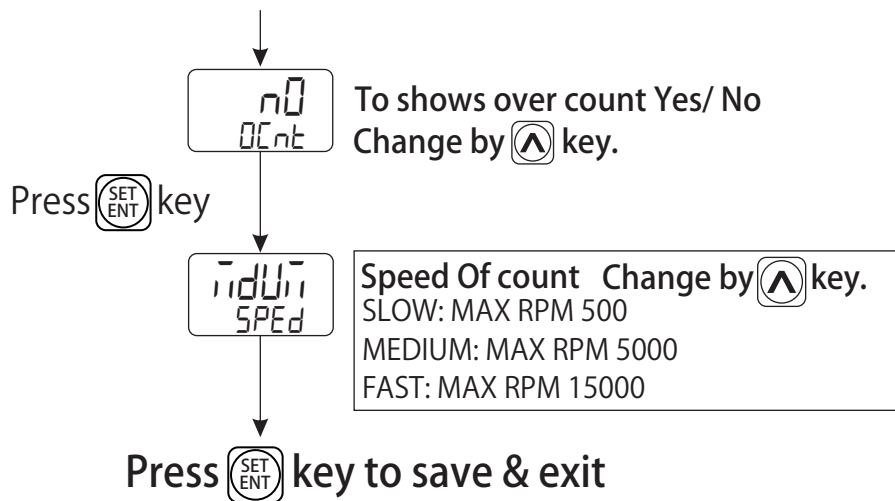

## Working

- 1). When pulse comes from sensor, upper display indicates Decrement in 'COUNT' in Instrument. Lower Display indicates 'Set Count Value'.
- 2). For Manual Mode, set time = 00.0 sec. and for Auto Reset Mode, set time = 00.1 to 99.9 sec.
- 3). When process value = Zero, Relay energizes. Relay remains ON for Auto Reset Time Relay turns off after completion of time. If time is set at 00.0 sec. then relay remains ON until key is pressed.
- 4). If there is a power failure the last reading is stored in the memory and Counter starts resume counting from the last stored value, when power ON.
- 5). To restart Counting or to Reset press key. Upper display will show set point and the counting will restart.
- 6). The proximity switch give pulse to counter every time the metal on the roller is sensed.

## Safety Precautions

All safety related codifications, symbols and instructions that appear in this operating manual or on the equipment must be strictly followed to ensure the safety of the operating personnel as well as the instrument.

If all the equipment is not handled in a manner specified by the manufacturer, it might impair the protection provided by the equipment .

=> Read complete instructions prior to installation and operation of the unit.

 **WARNING** : Risk of electric shock.

## Warning Guidelines

- 1) To prevent the risk of electric shock power supply to the equipment must be kept OFF while doing the wiring arrangement. Do not touch the terminals while power is being supplied.
- 2) To reduce electro magnetic interference, use wire with adequate rating and twists of the same of equal size shall be made with shortest connection.
- 3) Cable used for connection to power source, must have a cross section of  $1\text{mm}^2$  or greater. These wires should have insulations capacity made of at least 1.5kV.
- 4) When extending the thermocouple lead wires, always use thermocouple compensation wires for wiring for the RTD type, use a wiring material with a small lead resistance ( $5\Omega$  max per line) and no resistance differentials among three wires should be present.
- 5) A better anti-noise effect can be expected by using standard power supply cable for the instrument.

## Installation Guidelines

- 1) This equipment, being built-in-type, normally becomes a part of main control panel and such in case the terminals do not remain accessible to the end user after installation and internal wiring.
- 2) Do not allow pieces of metal, wire clippings, or fine metallic fillings from installation to enter the product or else it may lead to a safety hazard that may in turn endanger life or cause electrical shock to the operator.
- 3) Circuit breaker or mains switch must be installed between power source and supply terminal to facilitate power 'ON' or 'OFF' function. However this mains switch or circuit breaker must be installed at convenient place normally accessible to the operator.
- 4) Use and store the instrument within the specified ambient temperature and humidity ranges as mentioned in this manual.

## Mechanical Installation

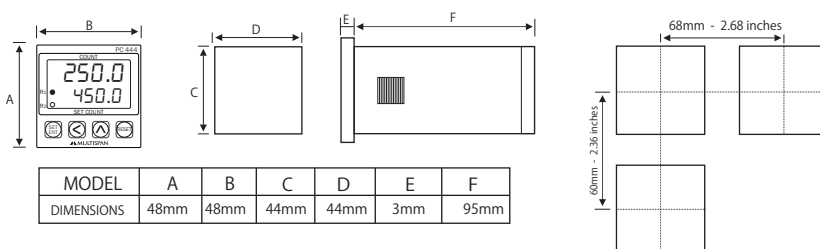

- 1) Prepare the panel cutout with proper dimensions as show above.
- 2) Fit the unit into the panel with the help of clamp given.
- 3) The equipment in its installed state must not come in close proximity to any heating source, caustic vapors, oils steam, or other unwanted process by products.
- 4) Use the specified size of crimp terminal (M3.5 screws) to wire the terminal block. Tightening the screws on the terminal block using the tightening torque of the range of 1.2 N.m.
- 5) Do not connect anything to unused terminals.

## Maintenance

- 1) The equipment should be cleaned regularly to avoid blockage of ventilating parts.
- 2) Clean the equipment with a clean soft cloth. Do not use isopropyl alcohol or any other cleaning agent.
- 3) Fusible resistor must not be replaced by operator.

Product improvement and upgrade is a constant procedure. So for more updated operating information and support, Please contact our helpline : +91-9978991474/76/82 or Email at [Service@multispanindia.com](mailto:Service@multispanindia.com) Ver: 04-2018